

## ASSEMBLY - 3.0 RAIL SYSTEM

\* Same steps apply for both Double Rail Systems and Triple Rail Systems.  
\* Compatible with hybrid tumbler.

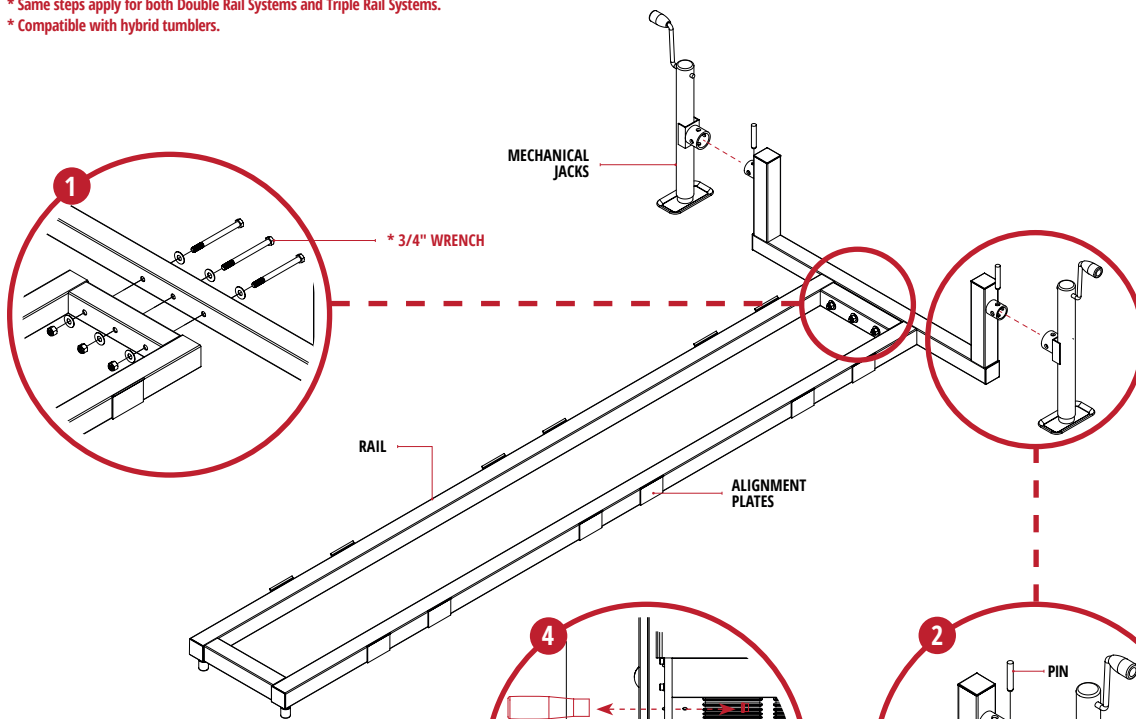

### STEP 1 WELDMENT CONNECTION:

CONNECT WELDMENT FRAME & WELDMENT UPRIGHT TOGETHER AS THE FIGURE ILLUSTRATES.

TIGHTEN BOLTS & NUTS TOGETHER USING A 3/4" WRENCH\* TO FIRMLY INSTALL THE TWO PARTS.

### STEP 2 MECHANICAL JACKS:

CONNECT THE MECHANICAL JACKS TO EACH SIDE OF THE WELDMENT UPRIGHT AS THE DIAGRAM SHOWS. USE PINS TO LOCK TOGETHER.

### STEP 3 MACHINE POSITIONING:

ROLL THE MACHINES, FRONT-TO-BACK, ONE BY ONE, OVER THE RAIL, AS CLOSE TO THE MECHANICAL JACKS AS POSSIBLE. KEEP THE MACHINES ALIGNMENT CENTERED TO THE WELDMENT FRAME. FINAL ALIGNMENT WILL TAKE PLACE ONCE JACKED UP.

\*REFER TO STEP 6

### STEP 4 REMOVE HANDLES: UNSCREW & REMOVE HANDLES.

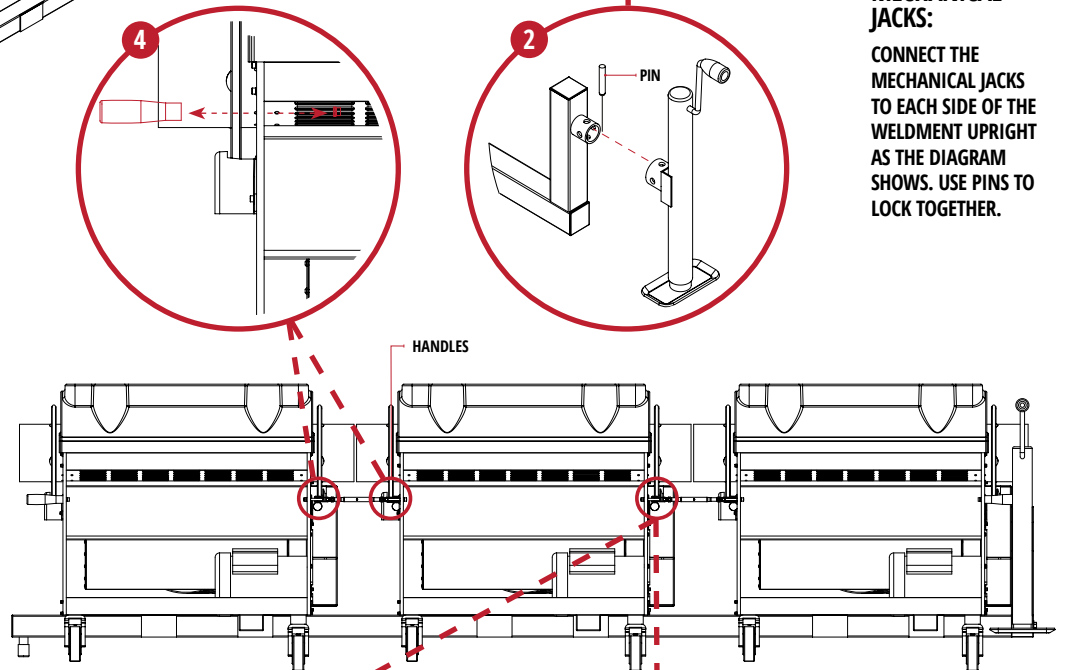

### STEP 5 CONNECTOR REPLACEMENT:

REPLACE THE HANDLE WITH TURNBUCKLE CONNECTORS, AND USE TURNBUCKLES TO LINK CONNECTORS ON BOTH SIDES. USE PIN TO LOCK TOGETHER.

FINAL ADJUSTMENTS WILL BE MADE IN \*STEP 7 AFTER THE UNIT IS RAISED.

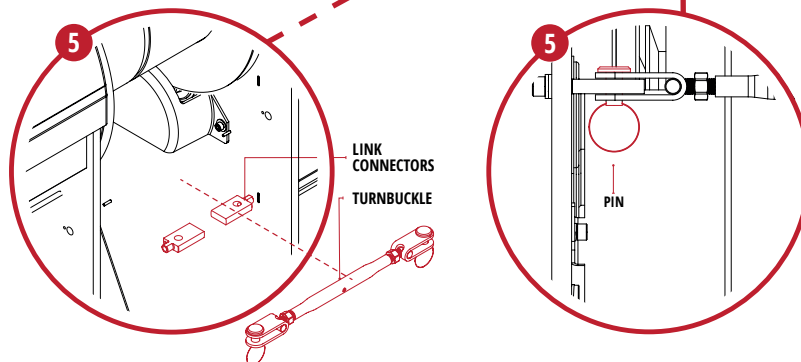

**LEARN  
HOW NOW**



## ASSEMBLY - 3.0 RAIL SYSTEM

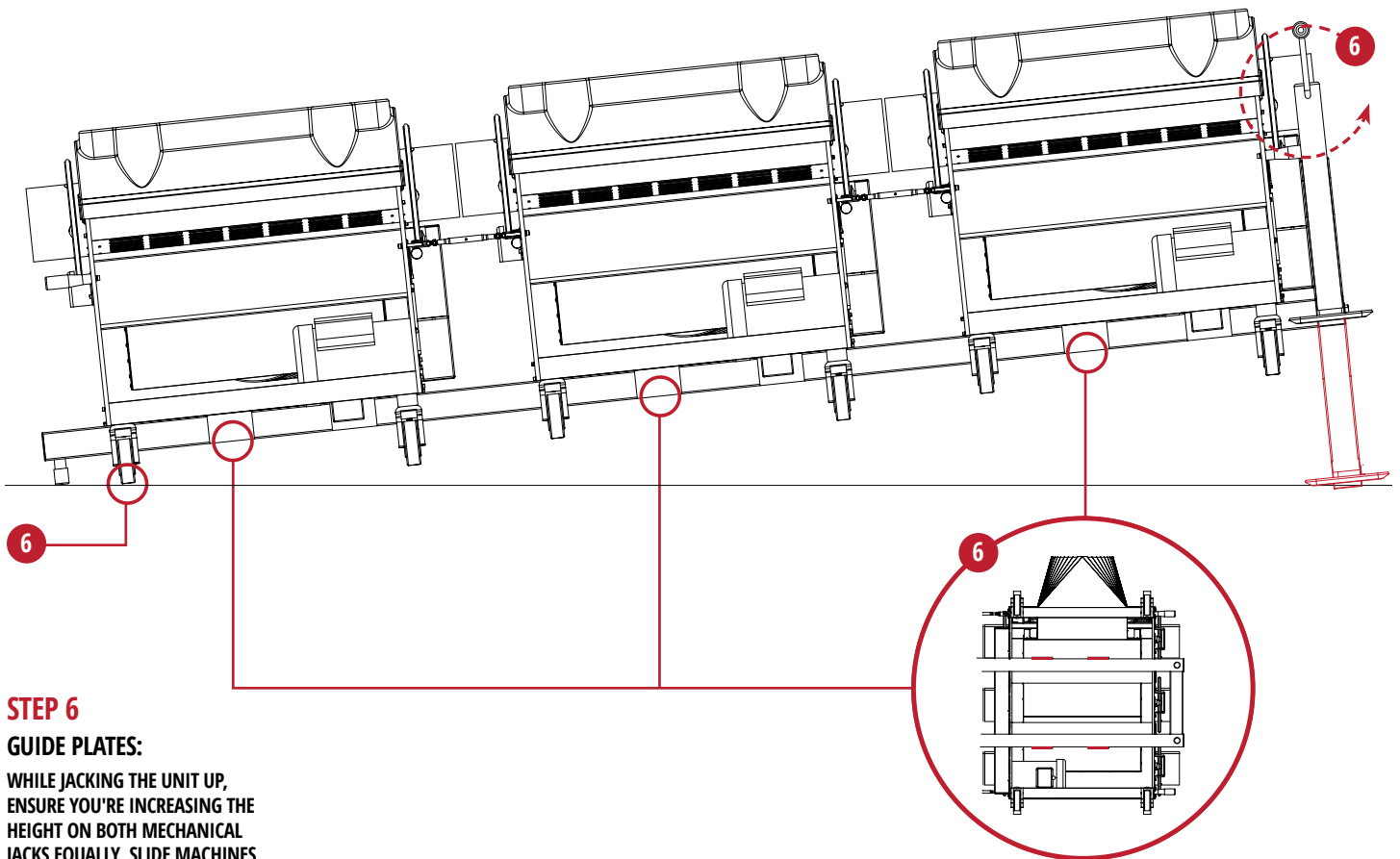

### STEP 6

#### GUIDE PLATES:

WHILE JACKING THE UNIT UP, ENSURE YOU'RE INCREASING THE HEIGHT ON BOTH MECHANICAL JACKS EQUALLY. SLIDE MACHINES INTO FINAL POSITION WITH THE HELP OF THE GUIDE PLATES.

RAISE RAIL UP TO THE MINIMUM HEIGHT, WHERE THE LAST TRIMMER CASTERS ARE JUST OFF THE GROUND.

IF THE CASTER IS UNABLE TO LIFT OFF THE GROUND MAKE SURE THAT THE FIRST TRIMMER IS UP ON THE RAIL AS MUCH AS POSSIBLE.

### STEP 7

#### TURNBUCKLE ADJUSTMENT

ADJUST GAP BETWEEN TWO MACHINES TO 1/8" - 3/16" BY TURNING TURNBUCKLES. TIGHTEN JAM NUT TO LOCK IN PLACE.

### STEP 8

#### BLOWER INSTALLATION:

USE HOSES AND CLAMPS TO CONNECT BLOWERS TO EACH UNIT.

